

# SILVERBACK GR SERIES

BLENDER SUCTION PUMPS  
MODEL 8X6X16 WPH-GR



## Pump Specifications

Size	8"x6"x16"
Casing	Carbon Steel
Impeller	Duplex Stainless Steel
Expeller	Duplex Stainless Steel
Impeller Shaft	17-4 Stainless Steel
Replaceable Wear Rings	Hardened Stainless Steel
Bearing Housing	Carbon Steel
Radial Bearing	Cylindrical Roller Bearing
Thrust Bearing	Duplex Angular Contact Bearings
Bearing Lubrication	Grease
Gasket	Modified PTFE (Acid Rated)
Weight	455 kg (1000 lbs)

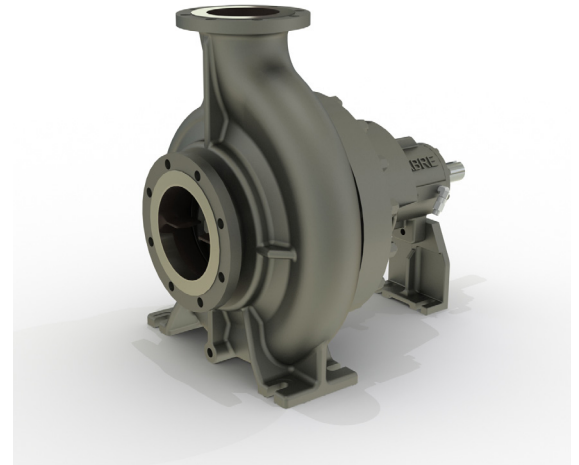

Min Speed	850 RPM
Max Speed	1750 RPM

## Pump Dimensions

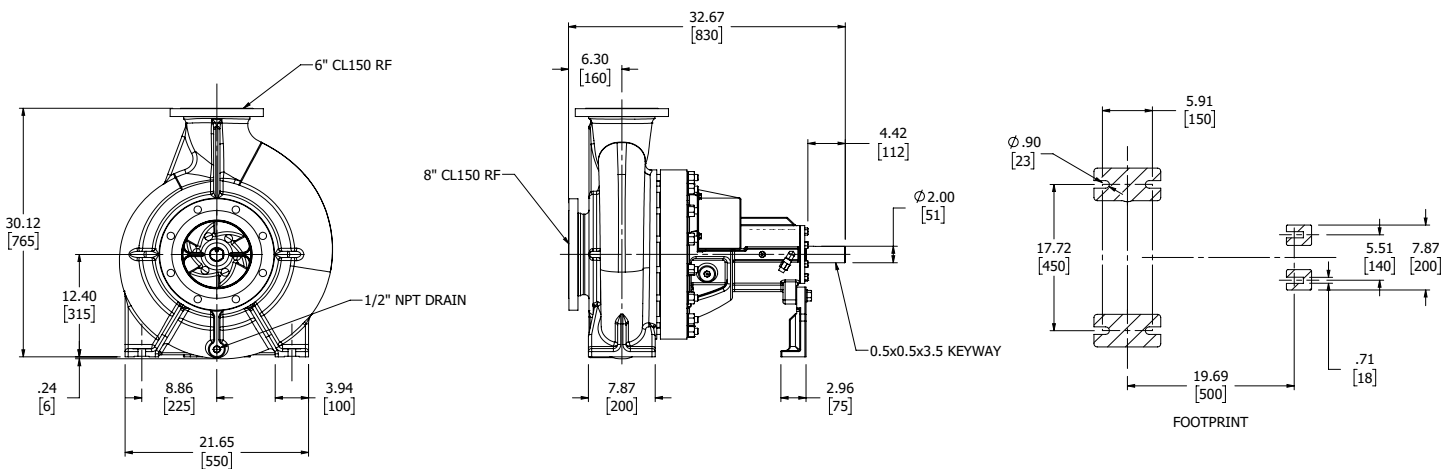

### Pump Performance

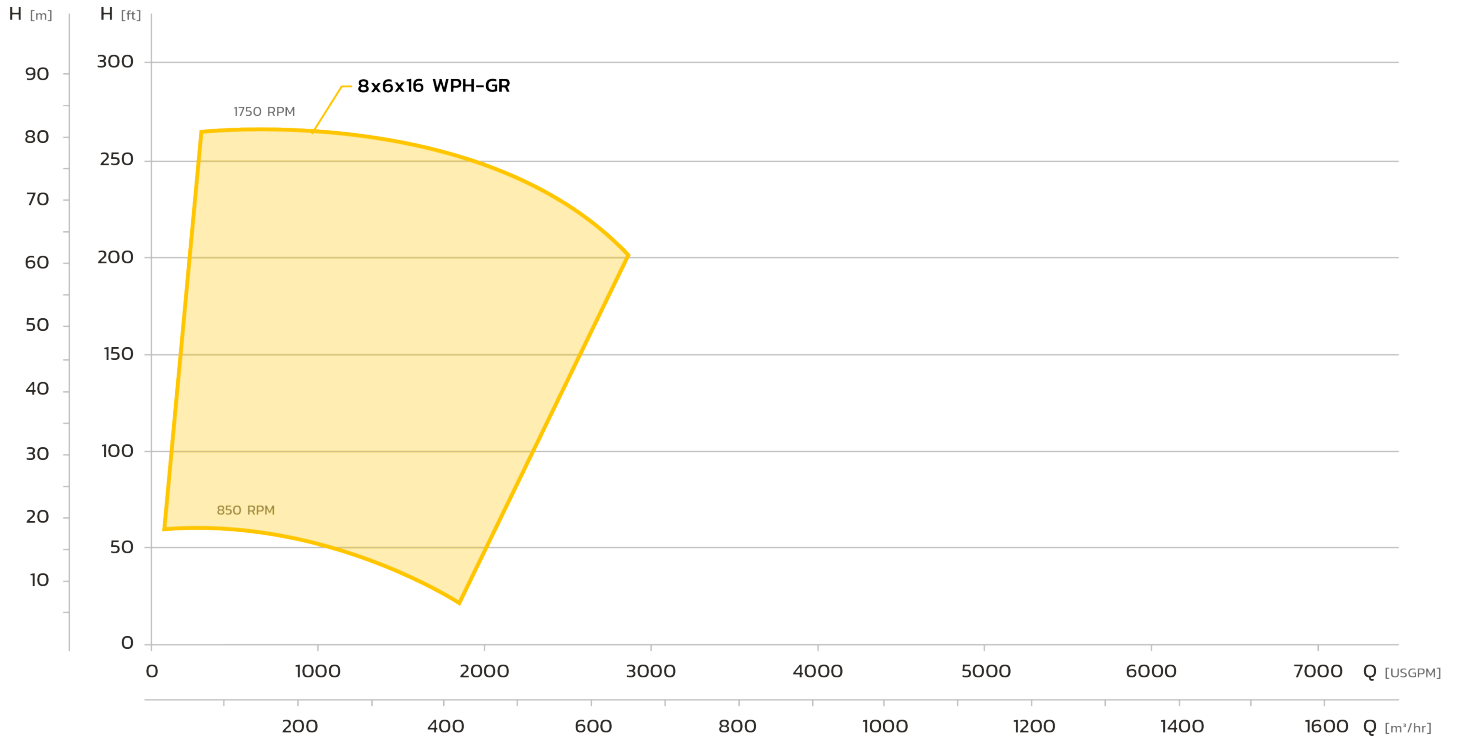

# SILVERBACK GR SERIES

BLENDER SUCTION PUMPS  
MODEL 10X8X16 WPH-GR



## Pump Specifications

Size	10"x8"x16"
Casing	Carbon Steel
Impeller	Duplex Stainless Steel
Expeller	Duplex Stainless Steel
Impeller Shaft	17-4 Stainless Steel
Replaceable Wear Rings	Hardened Stainless Steel
Bearing Housing	Carbon Steel
Radial Bearing	Cylindrical Roller Bearing
Thrust Bearing	Duplex Angular Contact Bearings
Bearing Lubrication	Grease
Gasket	Modified PTFE (Acid Rated)
Weight	500 kg (1100 lbs)

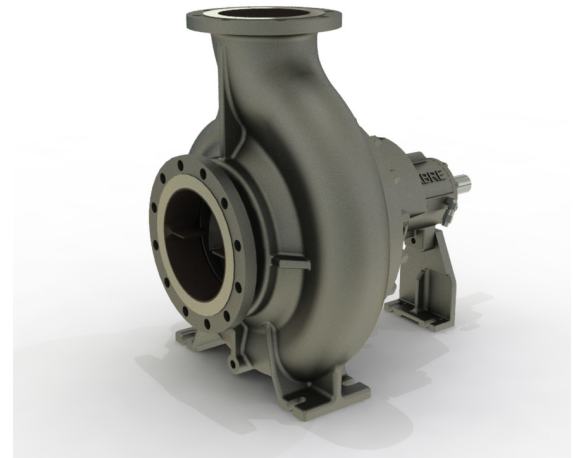

Min Speed 850 RPM  
Max Speed 1750 RPM

## Pump Dimensions

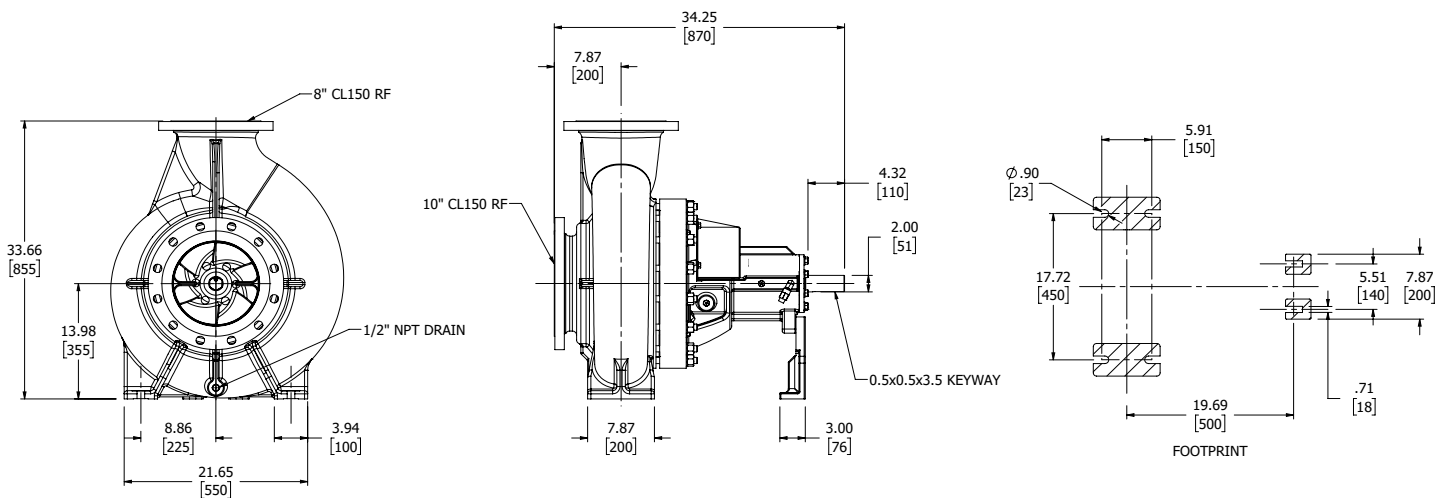

**/ Pump Performance**

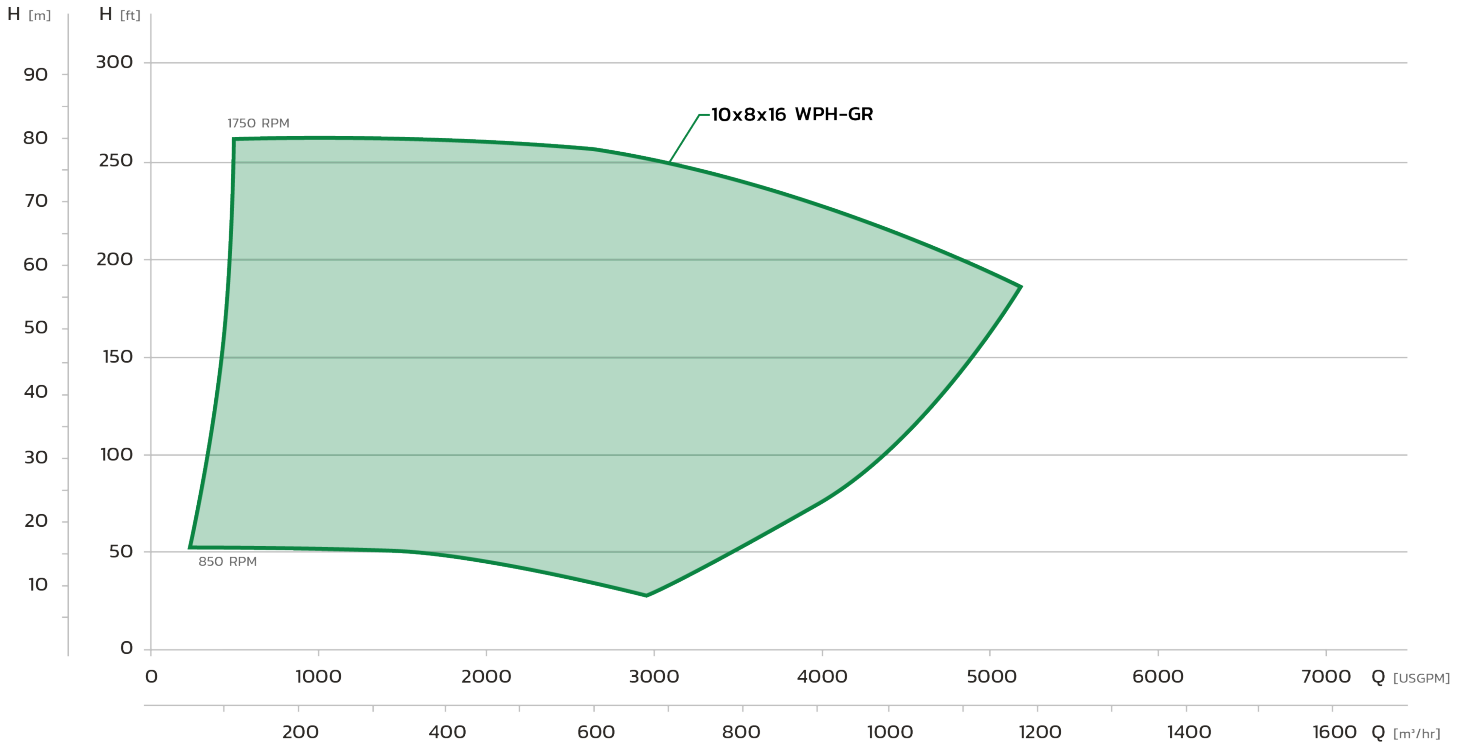

# SILVERBACK GR SERIES

BLENDER SUCTION PUMPS  
MODEL 12X12X15 WPH-GR



## Pump Specifications

Size	12"x12"x15"
Casing	Carbon Steel
Impeller	Duplex Stainless Steel
Expeller	Duplex Stainless Steel
Impeller Shaft	17-4 Stainless Steel
Replaceable Wear Rings	Hardened Stainless Steel
Bearing Housing	Carbon Steel
Radial Bearing	Cylindrical Roller Bearing
Thrust Bearing	Duplex Angular Contact Bearings
Bearing Lubrication	Grease
Gasket	Modified PTFE (Acid Rated)
Weight	545 kg (1200 lbs)

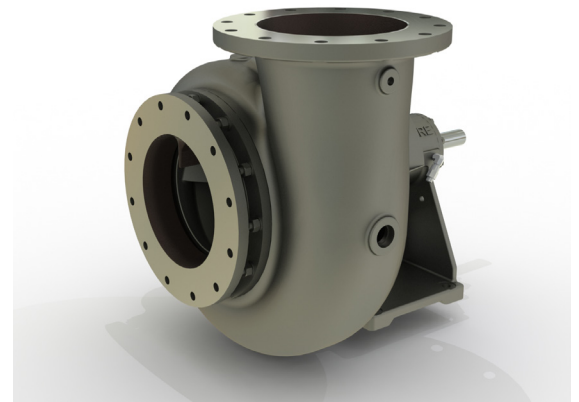

Min Speed	700 RPM
Max Speed	1250 RPM

## Pump Dimensions

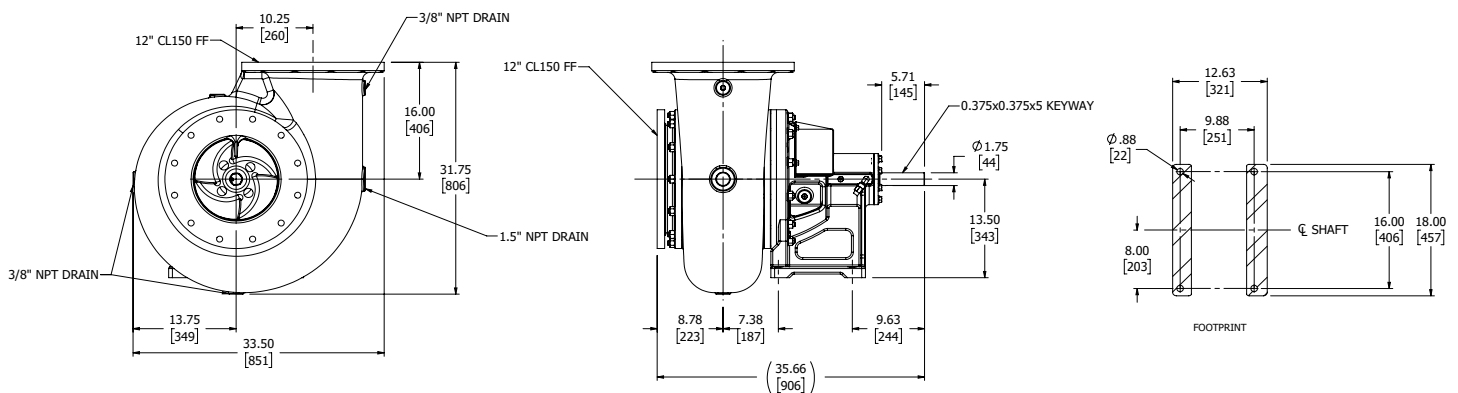

## Optional Suction Cover

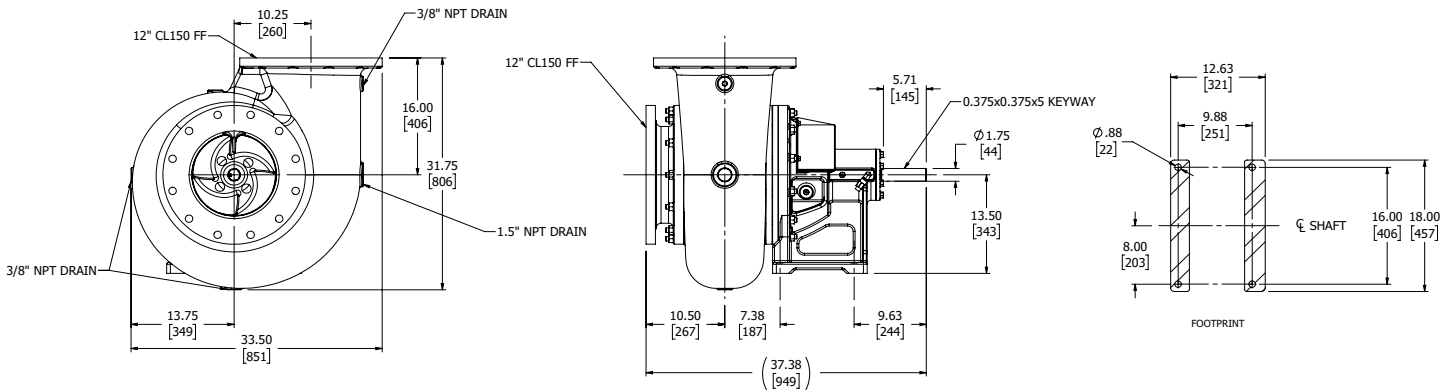

## Optional hydraulic motors support configurations available

## Pump Performance

