

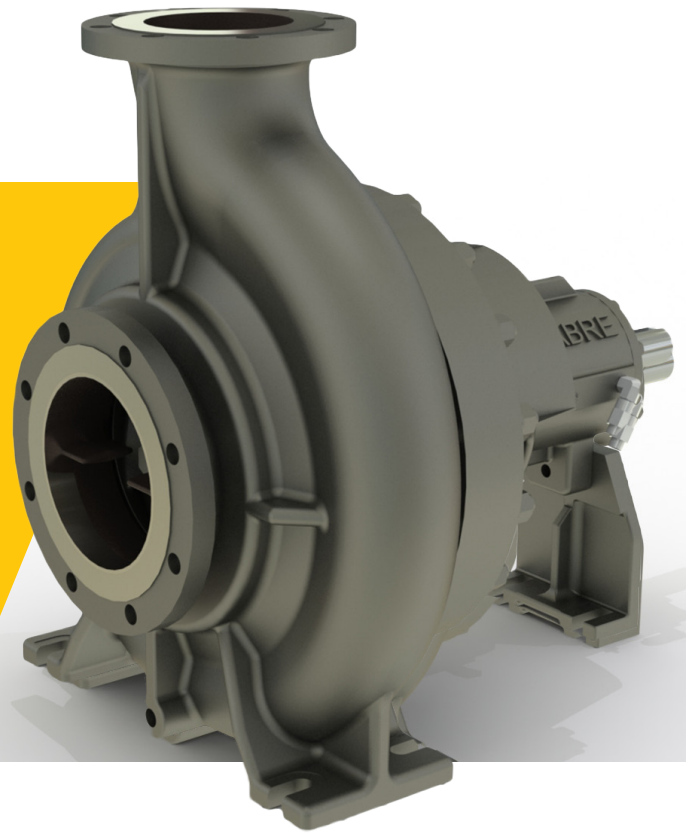

SILVERBACK GR SERIES

BLENDER SUCTION PUMPS



Raising The Bar

Silverback GR Series pumps have been created specifically to meet the challenges of the suction side of the frac blender. They are designed to stand up to continuous, high-volume pumping of fluids in a variety of clean and mild abrasive applications.

Our GR Series pumps are available in three standard sizes, each providing easy drop-in replacement for the most commonly used pumps: **8x6x16, 10x8x16, 12x12x15.**

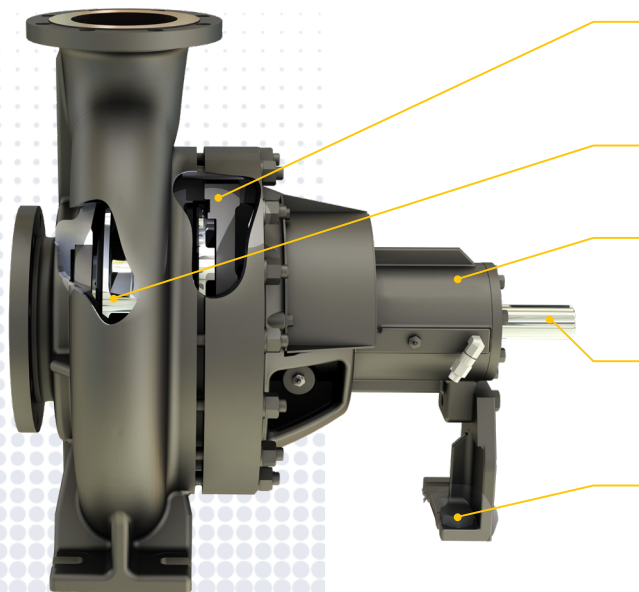

DYNAMIC SHAFT SEALING

Eliminates operating leakage and downtime due to mechanical seal failure.

ENHANCED CORROSION RESISTANCE

100% duplex stainless steel rotating components.

GREASE LUBRICATED BEARINGS

Reduces risk of bearing failures often seen with truck mounted oil lubrication.

LONGER LASTING

Higher capacity bearings and a larger, stiffer shaft reduces failures and extends life.

DROP-IN REPLACEMENT

Available in three sizes, these pumps have a footprint that easily replaces the most commonly installed pumps.

The Silverback GR Series is built for uptime.

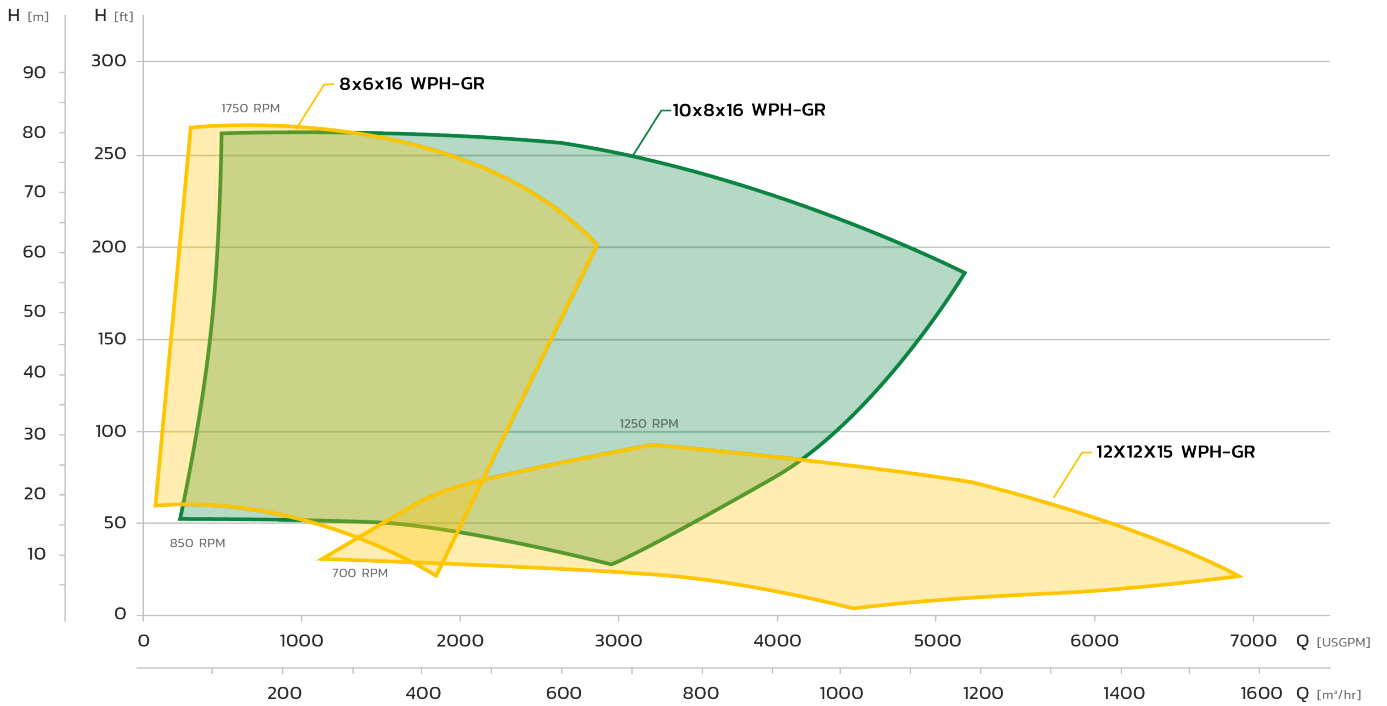

Key Benefits



IMPROVED RELIABILITY



VIRTUALLY MAINTENANCE FREE†



DROP-IN REPLACEMENT



REDUCED NON-PRODUCTIVE TIME



LOWEST TOTAL COST OF OWNERSHIP

† JUST GREASE THE BEARINGS

Relentless Work Ethic

IMPACT's Silverback family of hard working, extreme duty pump solutions are meticulously engineered and manufactured for those who demand predictability and peace of mind.

The Silverback GR Series Suction Pump is configured to make your life easier – with worry-free purchasing and ease of installation.

EXPECT THE BEST

BUILT STRONGER TO LAST LONGER

CONTACT

825-413-5747

sales@ipumps.com